

DIECUTEC

戴卡模切



戴卡模切

鸿太祥模切设备及技术事业部
H. SHINE Die cut equipment & technology sector

公司地址：中国广东省东莞市塘厦镇石潭埔工业区环市东路309号
邮 编：523717
电 话：+86 (769) 87942888 (18线) 87943688
传 真：+86 (769) 87889346
服务热线：+86 (769) 87923555 (6线)
网 址：www.diecutec.com / www.labelling.com.cn
电子信箱：htx@labelling.com.cn

鸿太祥戴卡模切设备及技术事业部
H. SHINE Die cut equipment & technology sector

公司简介

鸿太祥印刷机械有限公司是专业的商标印刷机、模切机制造商，地处广东东莞这一现代化工业制造名城。一直以来，我们本着对行业的兴趣与热情，不断创新，成为品种最全，产销量最大的商标印刷机、模切机制造商。

公司先后推出了150、210、270、300型不干胶商标印刷机、模切烫金机、多色高速轮转印刷机、品检分条机、晒版机、UV干燥机等各种商标印刷模切设备及配套设施。在国内率先成立模切事业部，以专注、专业、创新的精神引领模切机行业，拓展电子胶带产品模切领域，为一大批著名电子模切加工企业提供服务。产品广泛应用于吊卡、医药、食品、日化、IT、电子、胶粘、汽车、玩具、礼品、文具、超市条码等多个领域。而公司代理的各种国际流行商标印刷耗材，品种齐全，有专业印刷喷剂、双面胶带等，更可满足您印刷模切时的各种需求。

目前公司在国内多个地区设有分公司，产品销售网络遍布全国各主要城市及部分亚洲地区。无论您在哪里，鸿太祥人都能为您提供及时，优质的服务。同时我们也请您提供宝贵的意见和建议，使您所拥有的“戴卡模切”不仅成为中国的著名品牌，更成为世界一流的模切机。

H.SHINE PRINTING MACHINE CO., LTD, which is located at the modern city of China Dongguan (Guangdong Province), is specialized in manufacturing various kinds of label printing machines. With endless enthusiasm and great interest in the label field, we are always committing ourselves to the technological innovation, becoming a professional manufacturer of label printing presses with complete varieties and the largest produce and sale.

Our main products are Rotary Press, Letter Press, Roll to Roll CNC Screen Press, CNC Inspecting & Slitting Machine, Plate Making Machine and UV Drying Machine, etc. We take the initiative domestically in establishing the die-cutting focused sector, aiming at the aggressive and expanding electronic adhesive tape die-cutting market. With a devoted and innovative mind, We stay one jump ahead of the die-cutting division, providing lots of prominent electronic adhesive tape converters with quality machinery and good service. Those machines can print all kinds of labels and tags which can be widely used in clothes, medicine, food, daily necessities, electron, toy, gift, stationery and other fields. Also, we are agents of many international printing consumables, including letterpress inks, water-fast inks, environmentally friendly inks, numbering machines, color guide, professional printing die-cutting spray, double-surface tape and photopolymer printing plates.

Nowadays, we have many branches all over the nation. Wherever you are, you can receive our most timely service and support. Also, your valued feedback and opinions are our true assets. We are committed to make our products famous both at home and abroad. We are looking forward to cooperating with you in the near future. Please feel free to contact us.

非金属材料全自动冲型机

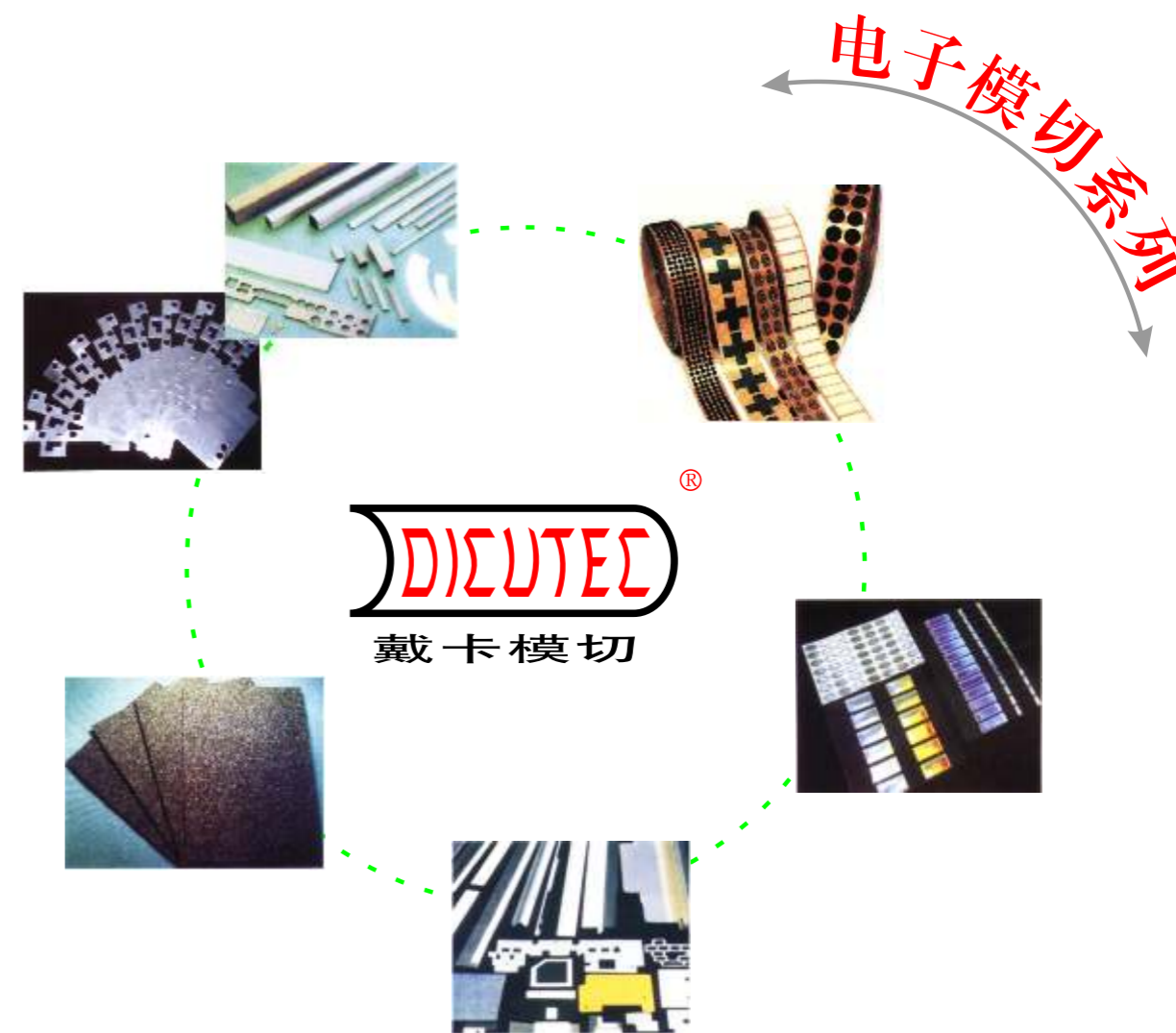

规格 SPECIFICATIONS:

型号 Model	JS-150D	JS-300D	JS-330D
模切面积 Die Cutting Size(mm)	150 × 125	300 × 300	330 × 480
最大纸宽 Max. Paper Width(mm)	160	310	330
最大拉距 Max. Paper Length(mm)	125	300	480
机械尺寸 Dimension L × W × H(mm)	1800 × 1000 × 1700	1800 × 1200 × 1800	2000 × 1350 × 1900
主马达功率 Main Motor Power(kw)	1.5	2.2	4.5
净重 Net Weight(t)	0.75t	2t	2.9t

型号 Model	JS-200D	JS-270D	JS-600D
模切面积 Die Cutting Size(mm)	200 × 190	260 × 190	600 × 440
最大纸宽 Max. Paper Width(mm)	210	270	620
最大拉距 Max. Paper Length(mm)	190	190	440
机械尺寸 Dimension L × W × H(mm)	1800 × 1100 × 1800	1800 × 1100 × 1800	2200 × 1500 × 2000
主马达功率 Main Motor Power(kw)	2.2	2.2	7
净重 Net Weight(t)	1.5t	1.5t	4.5t

● JS-150 拉杆单座模切机
JS-150 ONE STATION STANDARD
DIE CUTTING MACHINE

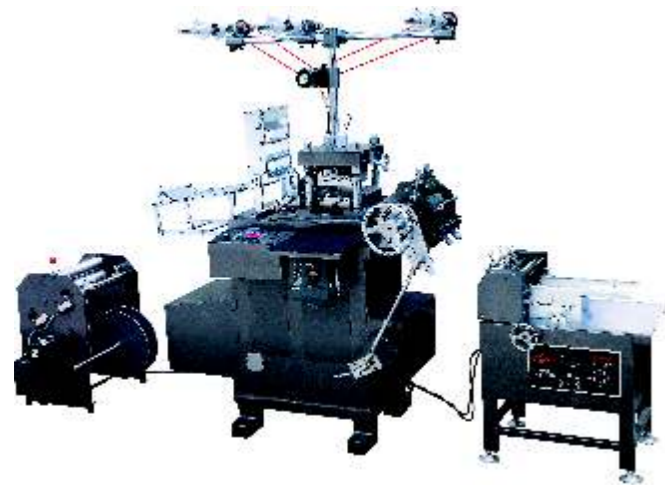

● JS-150 电脑单座模切机
JS-150 ONE STATION SERVO
DIE CUTTING MACHINE



● JS-270 电脑单座模切机
JS-270 ONE STATION SERVO
DIE CUTTING MACHINE



● JS-270 电脑双座模切机
JS-270 TWO STATION SERVO
DIE CUTTING MACHINE



● JS-200 电脑单座模切机
JS-200 ONE STATION SERVO
DIE CUTTING MACHINE



● JS-200 电脑双座模切机
JS-200 TWO STATION SERVO
DIE CUTTING MACHINE

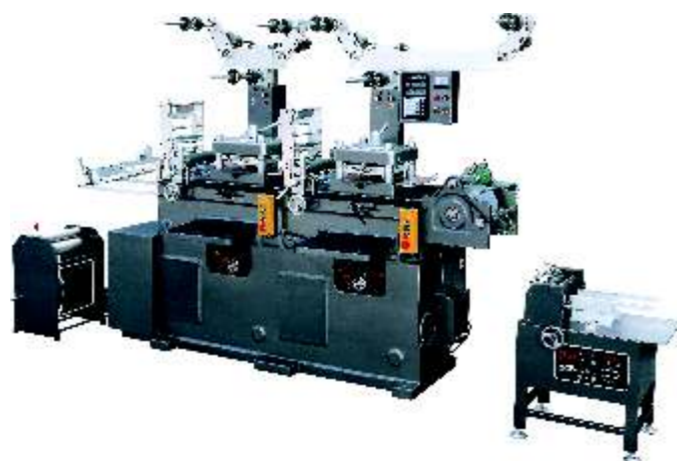

● JS-300 电脑单座模切机
JS-300 ONE STATION SERVO
DIE CUTTING MACHINE

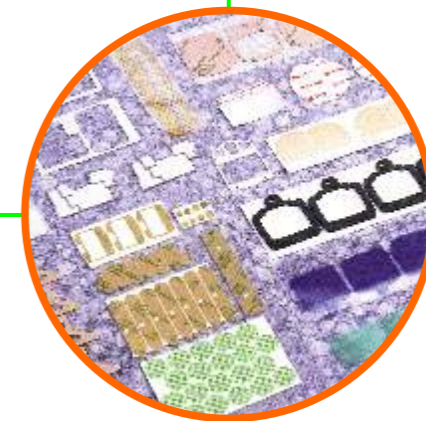

● JS-300 电脑双座模切机
JS-300 TWO STATION SERVO
DIE CUTTING MACHINE



● JS-500电脑单座模切机
JS-500 ONE STATION SERVO
DIE CUTTING MACHINE



● JS-600电脑单座模切机
JS-600 ONE STATION SERVO
DIE CUTTING MACHINE



横向烫金装置



除静电装置



伺服控制装置(基本配置)



安全保护装置

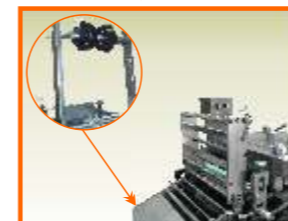
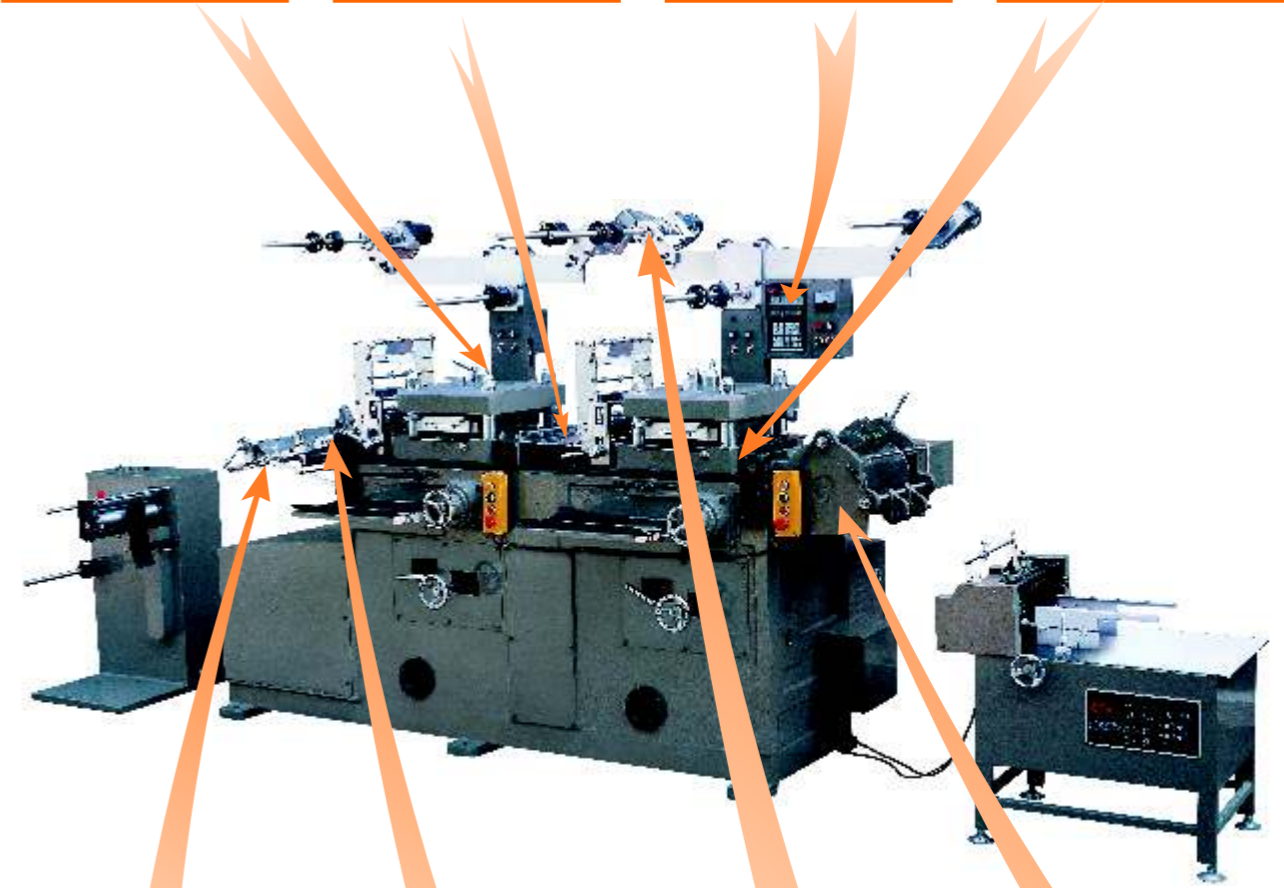

多层贴合放料装置



打孔装置



便利性收废装置



气压控制式拉纸头

● JS-330/JS-260圆模切机
JS-330/JS-260 ROTARY DIE CUTTING MACHINE





特性:

- 1、自动送料、收料、剥废、也可把贴合冲型集中在一起，使生产自动化。
- 2、卷装制作，速度可达到每小时12000次，成品可切可卷。
- 3、加装数控操作系统，电眼跟踪定位，可使产品达成二次复合、冲制。
- 4、噪声分贝小，使用者会处身于相对安静的冲制环境。
- 5、全自动操作在外围加装红外线安全设置（若有障碍物，伸进机器自动停机），使用时安全更有保障。
- 6、进料宽度有多种：150mm、200mm、270mm、300mm、330mm、500mm（单/双座工位），600mm（单座工位）。
- 7、该机器适用范围：电子、IT、汽车等制造行业。

Feature:

1. Automatic processing for feed-in, rewind, waste-peel; material-jointing and Die-cutting(shape-making) at same time.
2. Roll-to-roll product-making process; 12,000 times per hour; the finished products can be in sheet shape or roll shape.
3. Second time material-jointing and die-cutting by using computer-controlled servo moter system(by order).
4. Provide quiet working environment.
5. Infrared safty-guard system (machine stop running automatically under the condition of block.)
6. Feed-in size: 150mm ,200mm,270mm,300mm,330mm,500mm(one, two Station),600mm (one station).
7. Fields of applying: Electronic, IT, Auto

Applied Example



LCD用双面胶

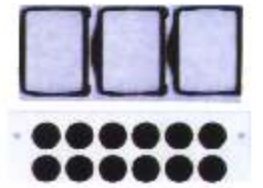

LCD用双面胶



MP3用双面胶



LCD用双面胶



PORON防震部品



LCD用双面胶



双面胶



手机镜片背胶

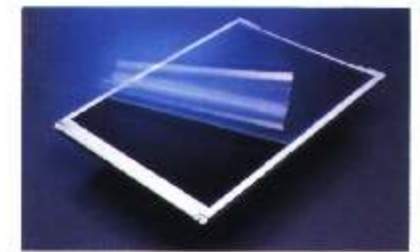

LCT显示屏保护膜



标签贴纸



标签贴纸



双面背胶





特性:

- 1、自动送料、收料、剥废、也可把贴合冲型集中在一起，使生产自动化。
- 2、卷装制作，速度可达到每小时12000次，成品可切可卷。
- 3、加装数控操作系统，电眼跟踪定位，可使产品达成二次复合、冲制。
- 4、噪声分贝小，使用者会处身于相对安静的冲制环境。
- 5、全自动操作在外围加装红外线安全设置（若有障碍物，伸进机器自动停机），使用时安全更有保障。
- 6、进料宽度有多种：150mm、200mm、270mm、300mm、330mm、500mm（单/双座工位），600mm（单座工位）。
- 7、该机器适用范围：电子、IT、汽车等制造行业。

Feature:

1. Automatic processing for feed-in, rewind, waste-peel; material-jointing and Die-cutting(shape-making) at same time.
2. Roll-to-roll product-making process; 12,000 times per hour; the finished products can be in sheet shape or roll shape.
3. Second time material-jointing and die-cutting by using computer-controlled servo moter system(by order).
4. Provide quiet working environment.
5. Infrared safty-guard system (machine stop running automatically under the condition of block.)
6. Feed-in size: 150mm ,200mm,270mm,300mm,330mm,500mm(one, two Station),600mm (one station).
7. Fields of applying: Electronic, IT, Auto

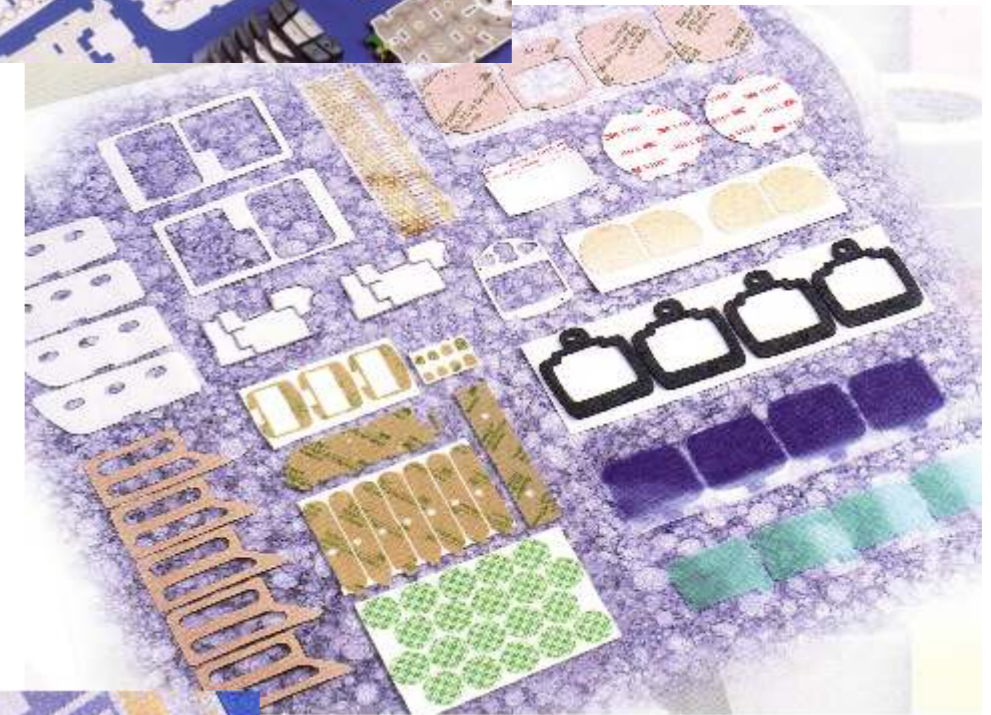



特性:

- 1、自动送料、收料、剥废、也可把贴合冲型集中在一起，使生产自动化。
- 2、卷装制作，速度可达到每小时12000次，成品可切可卷。
- 3、加装数控操作系统，电眼跟踪定位，可使产品达成二次复合、冲制。
- 4、噪声分贝小，使用者会处身于相对安静的冲制环境。
- 5、全自动操作在外围加装红外线安全设置（若有障碍物，伸进机器自动停机），使用时安全更有保障。
- 6、进料宽度有多种：150mm、200mm、270mm、300mm、330mm、500mm（单/双工位），600mm（单工位）。
- 7、该机器适用范围：电子、IT、汽车等制造行业。

Feature:

1. Automatic processing for feed-in, rewind, waste-peel; material-jointing and Die-cutting(shape-making) at same time.
2. Roll-to-roll product-making process; 12,000 times per hour; the finished products can be in sheet shape or roll shape.
3. Second time material-jointing and die-cutting by using computer-controlled servo moter system(by order).
4. Provide quiet working environment.
5. Infrared safty-guard system (machine stop running automatically under the condition of block.)
6. Feed-in size: 150mm ,200mm,270mm,300mm,330mm,500mm(one, two Station),600mm (one station).
7. Fields of applying: Electronic, IT, Auto

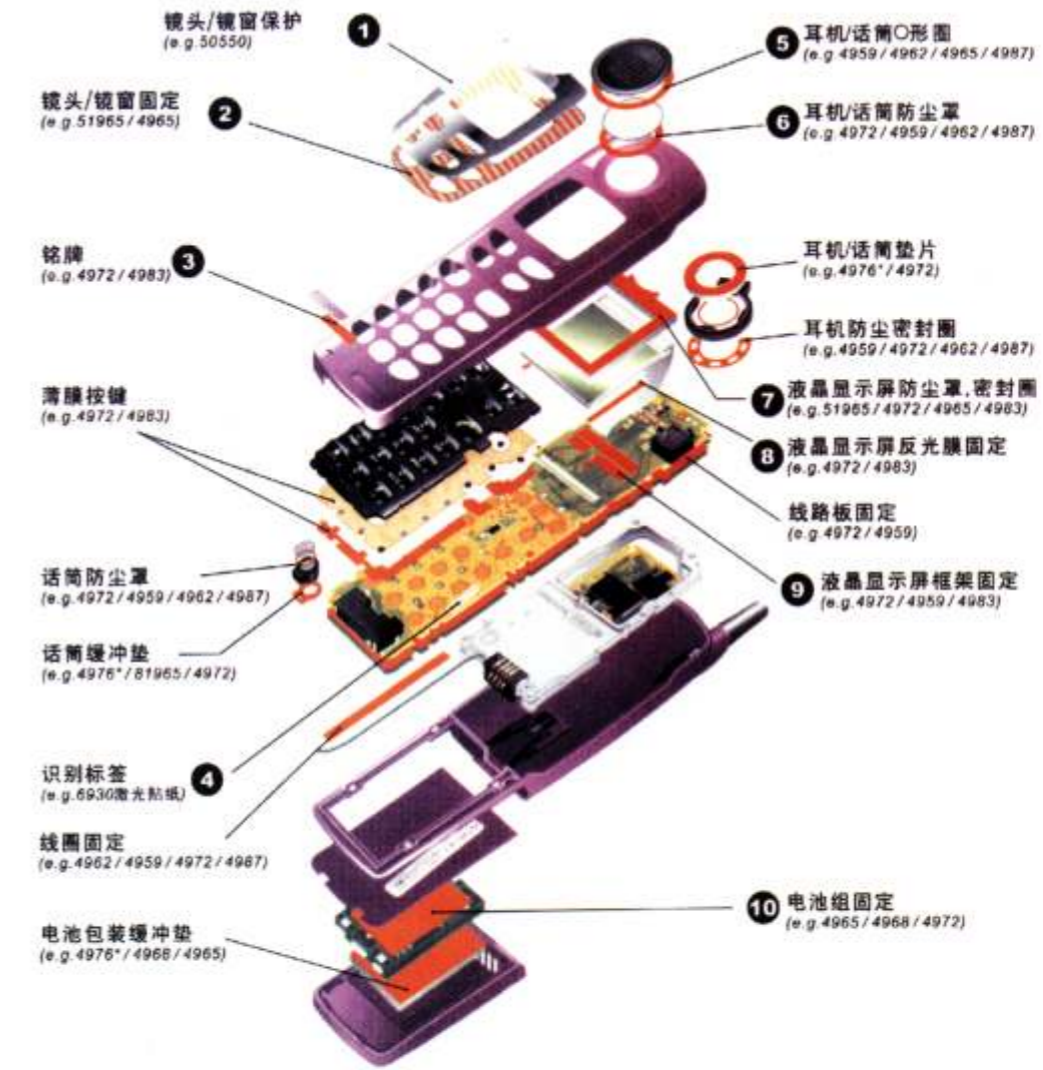

使用范围:

绝缘、EMI: 铜箔、铝箔、防火快巴纸、PET、PVC、牛皮纸，珍珠棉护套、海绵护套；
防震产品: 橡胶、回力胶垫、透明脚垫、3M、PORON垫、阻燃EVA、高发泡；
耐热隔热材料: 透明云母片、矽胶片、纤维布、隔热棉（布）；
胶贴产品: 各种电子、电器、手机特殊胶垫、魔术贴、硅胶贴、导电胶、强力双面胶、3M、日东、索尼等特殊胶贴；
防尘材料: 防尘网、无纺布、过滤棉、高密海绵、相机棉、化妆棉。
薄膜开关、背光屏等电子业、IT业、汽车制造业中所使用的胶贴产品。

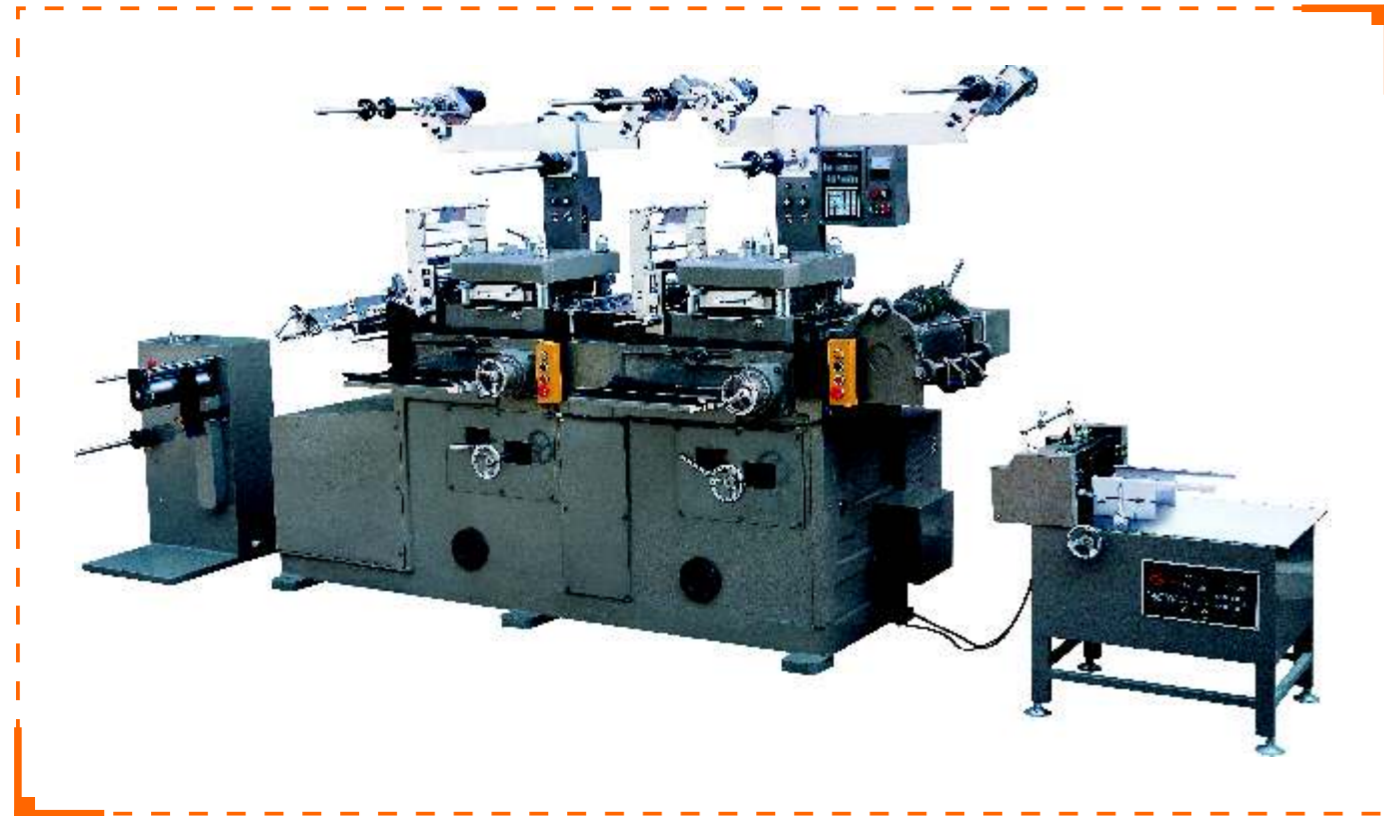

特性:

- 1、自动送料、收料、剥废、也可把贴合冲型集中在一起，使生产自动化。
- 2、卷装制作，速度可达到每小时12000次，成品可切可卷。
- 3、加装数控操作系统，电眼跟踪定位，可使产品达成二次复合、冲制。
- 4、噪声分贝小，使用者会处身于相对安静的冲制环境。
- 5、全自动操作在外围加装红外线安全设置（若有障碍物，伸进机器自动停机），使用时安全更有保障。
- 6、进料宽度有多种：150mm、200mm、270mm、300mm、330mm、500mm（单/双座工位），600mm（单座工位）。
- 7、该机器适用范围：电子、IT、汽车等制造行业。

Feature:

1. Automatic processing for feed-in, rewind, waste-peel; material-jointing and Die-cutting(shape-making) at same time.
2. Roll-to-roll product-making process; 12,000 times per hour; the finished products can be in sheet shape or roll shape.
3. Second time material-jointing and die-cutting by using computer-controlled servo moter system(by order).
4. Provide quiet working environment.
5. Infrared safty-guard system (machine stop running automatically under the condition of block.)
6. Feed-in size: 150mm ,200mm,270mm,300mm,330mm,500mm(one, two Station),600mm (one station).
7. Fields of applying: Electronic, IT, Auto



1、橡胶件的固定

胶带具有良好的剥离强度和抗剪强度，以保证在使用时持久的粘接效果；
高剥离强度可以防止高温下橡胶件脱落；

2、PCB的保护

PET基材胶带可以提供良好的电绝缘性；
优秀的抗剪切强度可防止保护膜从机壳上滑落下来；
具有较高剥离强度的双面胶带能够保护硬盘免受损伤；

3、内存卡

具有良好粘接性的胶带可以确保模块的长久使用；
良好的耐温性确保即使闪存卡暴露在阳光下也能可靠粘接；

4、LCD缓冲垫的固定

在机械固定前需可靠的临时粘接，因此需要胶带具有中等粘接力；
良好的抗湿性确保胶带不会因为湿度变化发生粘接失效；
胶带具有中等粘接强度和高强度的PET基材，使得被粘接泡棉在相机维修时能够被无破坏剥离；

5、按钮及硬件质材料的固定

高强度的PET 基材使得胶带便于各种复杂的模切；
中等的粘接强度使装配过程中的初始重新定位成为可能；

6、镜盖的固定

良好的剥离强度和抗剪强度可以确保镜盖在受到外力时仍然能够被可靠固定；
良好的防潮性能可以防止镜盖受潮后翘起；

7、闪光灯电池/缓冲垫的固定

胶带具有较高的初始剥离强度，并能快速粘接被粘表面，
可以确保加工过程中零件不会掉落；
中等粘接力使得粘接部位可以承受中等外力；

8、反光膜的固定

较小的厚度公差确保了平滑的粘接；
反光膜与LCD负责之间的距离应最小化以避免光的损失；
中等粘接力确保LCD装配前的可靠固定；

10、LCD模块的固定

在装配过程中胶带能够与被表面迅速粘合，不会造成LCD模块的滑落；
在机壳装配之前中等强度的粘接力可以确保LCD模块临时的粘接固定。

适用范围:

适合纸张不干胶商标、涤纶薄膜商标及镭射防伪商标的模切，特别适用于电子业PET、PP、PVC、粘胶、不织布、绝缘材料、屏蔽材料的冲孔、成形、多次复合等综合加工，是取代传统冲床加工的最佳选择。

Range of applying:

It is the best selection for you, which can replace the traditional punch. Suit for paper pressure sensitive label, terylene film label, radium ray counterfeit-guard label. And especially it is applicable for the materials used in the electronic industry-like PET, PP, PVC, adhesive, non weaving, insulated material and shield material - by punching, shaping and frequent compounding and other complex processes.



特点:

该机以电脑伺服拉纸系统，配有二度电眼，跟踪定位装置，进料→复合（冲孔）→模切→排废→切片（收卷）一次性完成。有150、200、270、300、330、500、600等单/双座机型。

Feature:

The machine's paper - drawing function is controlled by servo motor. And combined with bis electronic eye, tracking and registering devices. Its material feeding, laminating, die-cutting, waster peeling and slicing up(or rewinding)are accomplished in one process. One-station and two-sation of JS-150, 200,270,300,330,500,600 etc..



Applied Example



- 1.胶贴产品:** 各种电子、电器、手机特殊胶垫、硅胶贴、魔术贴、导电胶、强力双面胶、日东、3M、索尼特殊胶贴、背光屏等电子业、IT、薄膜开关、汽车制造业中所用的胶贴产品。
Bonding Products: diversified electronic, electrical appliance, mobile phone special rubber cushions, silicone rubber cushion, magic tape, electric conductive tape, powerful double side adhesive, Suneats, 3M, Sony special binding products, tapes for backlight screen, electronic industry, IT, film switch and car making industry.
- 2.防尘材料:** 化妆棉、相机棉、高密海绵、过滤棉、防尘网、无纺布。
Dustproof materials: cosmetic cotton, camera cotton, high density sponge, filtering sponge, dust net and non-woven fabric.
- 3.防震产品:** 回力胶垫、橡胶、透明脚垫、PORON垫、3M、阻燃EVA、高发泡。
Shock Absorbing Products: EVA tape, rubber, transparent cushion, PORON cushion, 3M, inflammable retardant EVA, high foam.
- 4.绝缘、EMI:** 防火快巴纸、铝箔、铜箔、PVC、PET、牛皮纸、海绵护套、珍珠护套。
Insulation, EMI: fireproof paper, aluminum foil, copper foil, PVC, PET, brown paper, sponge sheath, pearl cotton sheath.
- 5.耐热隔热材料:** 矽胶片、透明云母片、纤维布、隔热棉(布)。
Heat Insulation Materials: Silicone sheet, transparent mica, fiber cloth, heat insulation cotton (fabric).



自由的调整角度，配合取料或贴材时，保证产品的品质



全自动运作，废料取走，取走角度及位置调整



硬度85°的主胶轴，更理想的配合贴合



胶纸与胶片贴合，可做精密压力调整及间隙厚薄调整

示意图
Sketch map

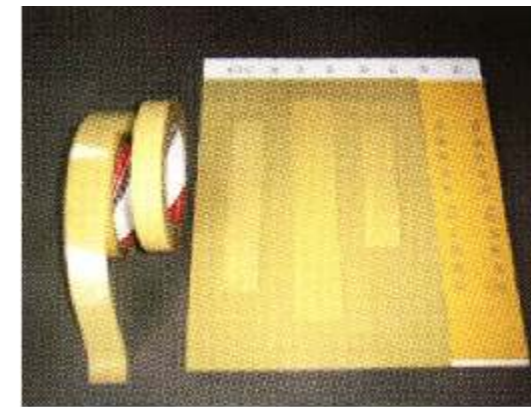
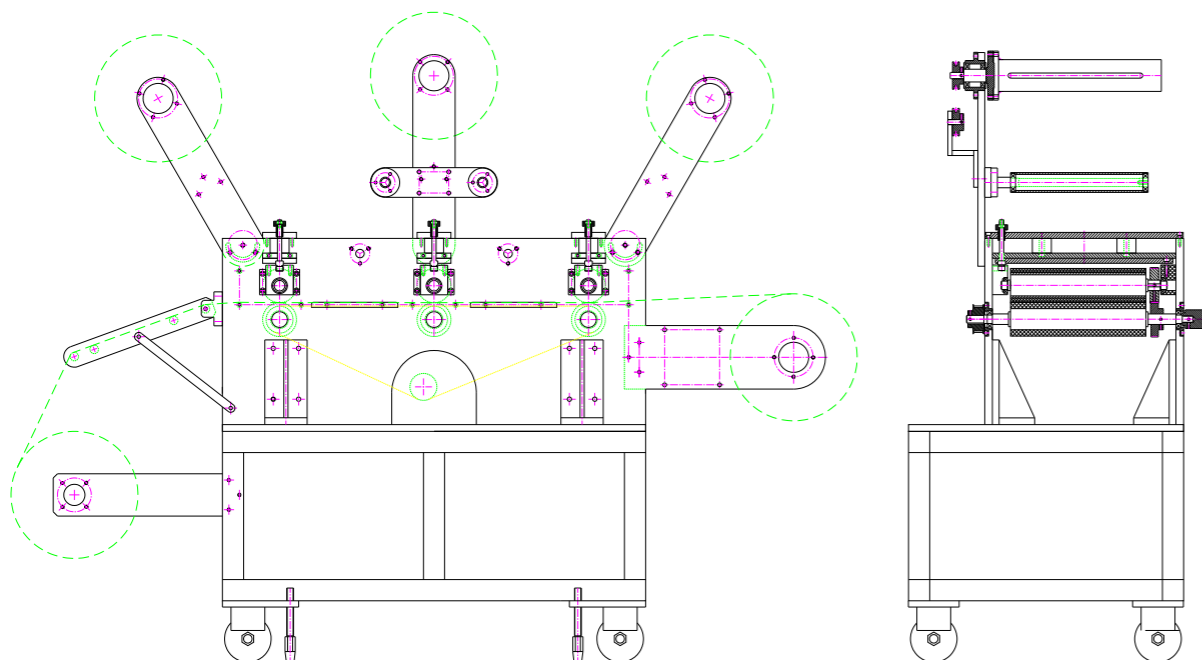

多功能贴合机
MULTIFUNCTIONAL LAMINATING MACHINE



特点:

- 1、贴合宽度可达300、600、800mm。
- 2、贴合离型纸剥离可一次性完成。
- 3、可两正一反双面胶、也可根据客户要求订做。
- 4、可二次贴合多层双面胶。

Specialty:

1. max width of jointing:300、600、800mm
2. Jointing and released paper peeling at same time.
3. Jointing the material two times at front side and one time back side, cor to be ordered.
4. Two times jointing multi-layer double-side tape.

适用范围:

电子工业用单、双面胶带，耐高温双面胶带，导热双面胶带等各种需要粘合的材料。

Range of applying:

Process one-side or double-side tapes of electronic in industry, Heat-proof double-side tape and heat-conducting tape ,etc.

全自动卷对卷连续式丝网印刷机 (单/双色)
FULLY AUTOMATIC ROLL TO ROLL CONTINUOUS SCREEN PRINTING MACHINE

特点:

该机结构合理,操作方便。采用了UV干燥系统、伺服马达拉纸系统,同时,配有自动送纸装置和自动卷纸装置。达到了高质量和高速度印刷效果,适用于各行业平面丝印。

Specialty:

Reasonable structured. Easy operating. Equipped with UV-drying and motor servo controlled dray sheet system sheet system. Allocating the automatic feeder and rewinder. High quality and high speed printing effect. It can meet all trade and professions' requirement for flat screen printing.

参数:

印刷面积: 300×300mm
 网框面积: 450×450mm
 最大进纸宽度: 320 mm
 电压 / 功率: 220V / 0.8kw
 印刷速度: 0~3600次/小时

Specification:

Printing size: 300×300mm
 Screen frame size: 450×450mm
 Max.paper width:320mm
 Work tension / power: 220V / 0.8kw
 Printing speed: 0~3600impressions/hour

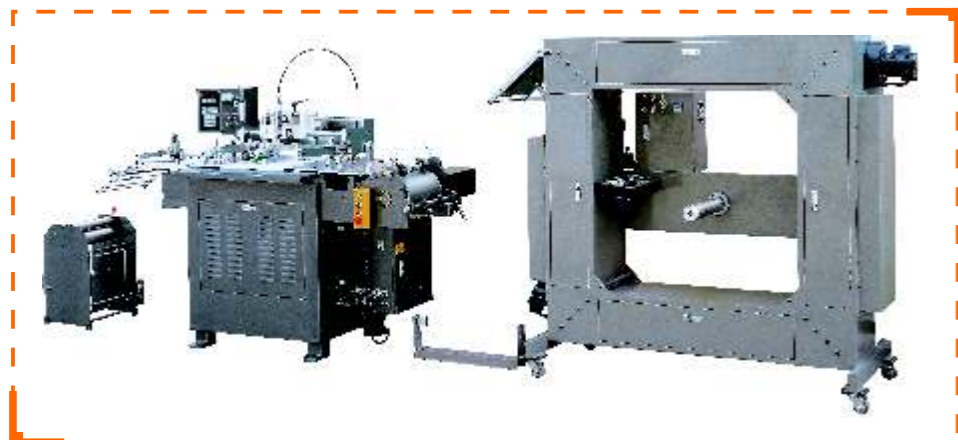

◆应用范例
Applied Example

该机适用于特殊材料PVC、PET等标签印刷,并适用于各行业广告标牌印刷等等。

This machine is employed to converting special label materials like PVC. PET, as well as other labels and taps on various fields, etc.

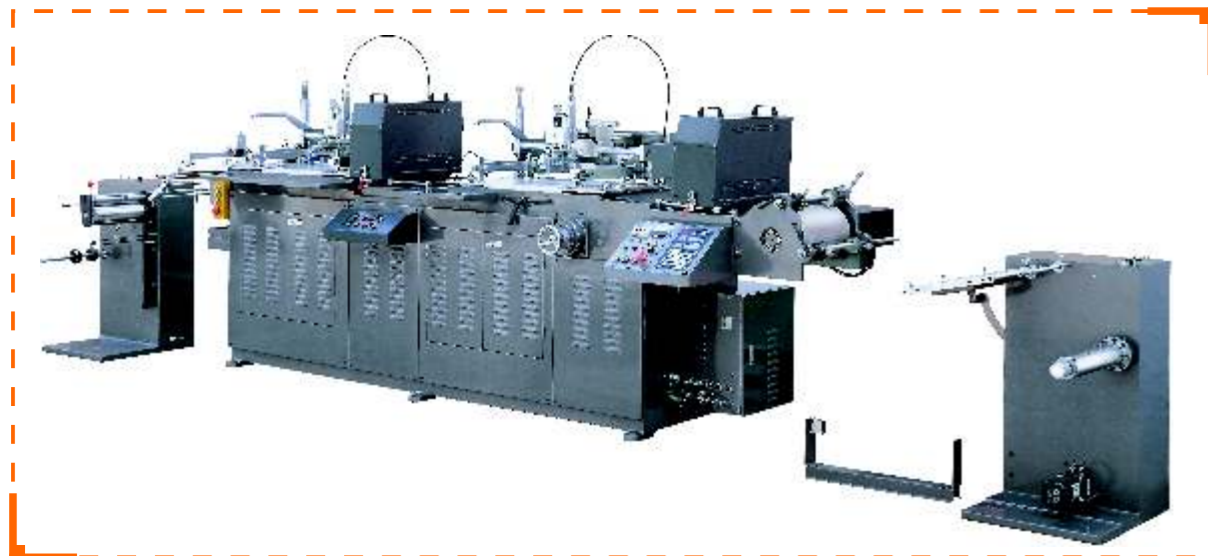

多功能高速电脑分切机
HIGH-SPEED AUTOMATIC CUTTER MACHINE

功能特点:

该机设有光电跟踪、自动纠偏、自动计米、张力可调等功能操作维护方便,能分切各种印刷包装用的聚丙烯、聚乙烯、塑料薄膜、复合材料、金属铝箔、水松纸、糖果纸、电报纸、计算机纸、玻璃纸、香烟纸、卫生纸等。

Specification:

This machine armed with all kinds of powerful functions like: photoelectric tracking, automatic deviation rectifying and self length measuring, as well as tension adjusting. It can process a wide range of materials on printing and packing industry, such as: polypropylene, polyethylene, and other sheet film alike, filter plug wrap paper, candy paper, telegraph paper, calculating-machine paper, glassine, cigaretter paper, and sanitary tissue.

主要技术参数:

主机功率: 3KW
 分切速度: 16~300米/分
 上卷最大直径: 600毫米
 收卷最大直径: 400毫米
 整机重量: 2.8吨

Parameter:

Power: 3KW
 Cutting Speed: 16~200m/min
 Max. unwinding diameter: 600mm
 Max. rewinding diameter: 400mm
 Machine Weight: 2.8t

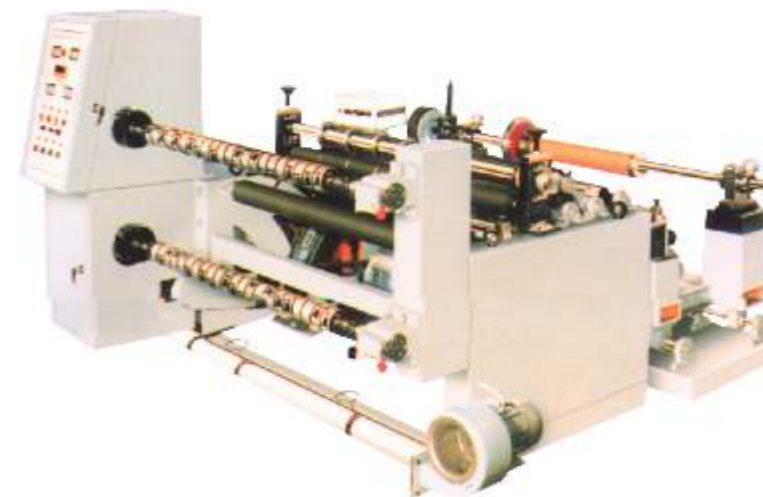

双轴自动裁切机
AUTO DOUBLE ROOL CUTTING MACHINE

用途:

适用于PVC/BOPP/PE/美纹纸/双面胶/牛皮纸等胶带之裁切。

APPLICATIONS:

Suitable for PVC/BOOP/PE/Mask/Double-side/Kraft ect tape to cut.



JS型分条机 (JS330, 1100, 1300)
JS SLITTING MACHINE (JS330, 1100, 1300)

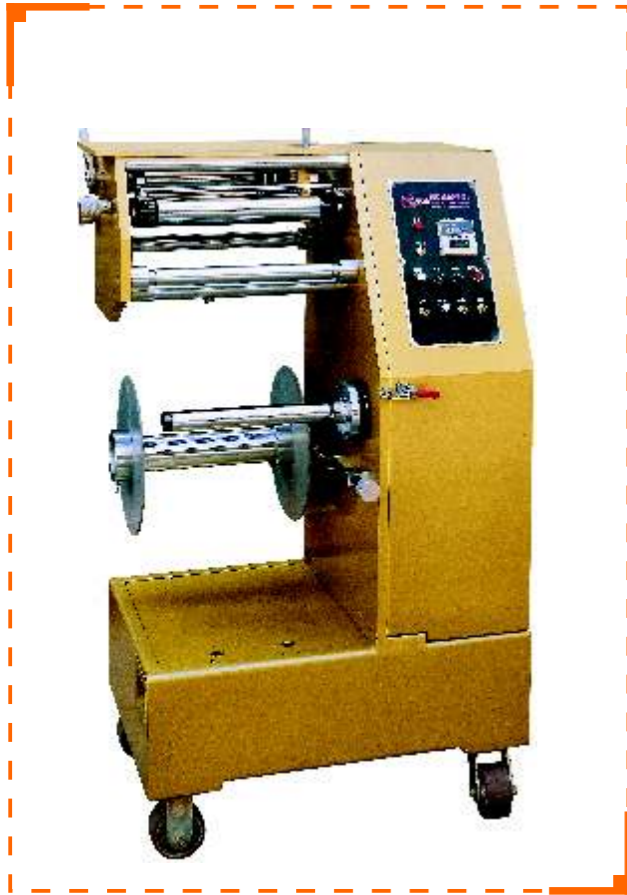

参 数:
 分切速度: 0~50mm/min
 最大分切直径: 400mm
 最大收卷直径: 400mm
 最大分切宽度: 300mm
 最小分切宽度: 12mm
 电机功率: 0.75kw
 工作电压: 220V
 常规刀配备: 6套
 放卷纸筒直径: 3"
 收卷纸筒直径: 3"

Specification:
 Split speed: 0 ~ 50mm/min
 Largest split cutting diameter: 400mm
 Largest delivery roller width: 400mm
 The largest split cutting width: 330mm
 The smallest slitter width: 10mm
 The electric power: 0.75kw
 Work tension: 220V
 Standard blade outfit: six pairs
 Pull winding of paper roller diameter: 3"
 Receive winding of paper roller diameter: 3"

特点/Feature:

本机采用先进设计, 包括张力控制器, 变频装置, 进口刀片组保证了更高的分切品质。适用于宽度330mm以内的空白或成品卷装分切。

This model use the advanced design, including the tension control device, electric converter facility, imported blade combination, ensure high er quality of splitting shear, being applicable within the width of 330mm's blank or turn off roll material split cutting.

美国仕必威945#润滑剂
SPRAYWAY 945 LUBRICANT



特点:

- 1、防止溢胶
- 2、可消除粘附、润滑多种表面, 干化迅速。

Specification:

1. To avoid glue-spilling.
2. Prevent lasting adhibition, lubricate many different material at surface, dry fast.

适用范围:

防止刀具与双面胶带粘连, 改善工况。

Boundary:

To prevent the stickness and adhesiveness between the cutting tool and the double-side tape, and improve the working condition as well.

注册商标
TRADE MARK



此标志与“嘉盛印机”, “嘉盛”, “戴卡”, “ENG”, “DICUTEC”为我公司注册商标, 严禁仿冒, 违者必究。

The sign on the right together with "嘉盛印机", "嘉盛", "戴卡", "ENG", "ENG JIASHENG", "DICUTEC" is our registered trade mark. Any imitation action will be strictly prohibited. We preserve the legal right of bringing an accusation against the imitator(s).

国家专利
NATIONAL AUTHORIZED PATENT



公司拥有专利号ZL 01 2 42947 3 的实用新型不干胶印刷机专利权, 望客户认清商标—嘉盛印机, 谨防假冒。
 H.SHINE owns a National Authorized Patent (ZL 01 2 42947 3) for New Type Practical Pressure Sensitive Label Printing Presses. Please make sure your selected brand---"ENG JIASHENG".



公司拥有专利号ZL 2005 3 0068240.7的商标轮转印刷机外观设计和ZL200520063817.X的商标轮转印刷机实用新型凸版印刷座专利权, 望客户认清商标—嘉盛印机, 谨防假冒。



CE认证书